

Resilmount A96R

Purlin to Furring Channel Sound Isolation Bracket

APPLICATION

Resilmount A96R is an engineered, patented adjustable acoustic resilient bracket for Studco furring channels being suspended below purlins or trusses, for reducing airborne vibration and structure-borne vibration in ceiling applications.

FEATURES

- Unique, patented sound cell design to break up and absorb airborne sound.
- Engineered thermoplastic rubber outperforms standard rubber because of its sound absorbing characteristics.
- A96R gives ceiling height flexibility.
- Allows for mechanicals between the ceiling and ceiling joists.
- Can be used with standard drywall furring channel.
- Strong 'column' design provides minimal contact area with substrate whilst maintaining maximum structural integrity.
- Provided with several 3/16" slotted holes in bracket surface, suitable for direct fastening applications.

INSTALLATION NOTES

- A96R to be fastened to structure with a minimum #8 screw or masonry sleeve anchors. (See fasteners manufacturers specifications).
- Load capacity: 55lbs. maximum dead load
- Maximum spacing of clips on furring channel is 48".
- Spacing between furring channel channels should not exceed 24".

FASTENERS

Wood Joists: #8 x 2" Course Heads (A)
Steel Joists: #8, #10 or #12 x 1-5/8" self tapping (B)

DYNAMIC CHARACTERISTICS

The Resilmount A96R sound isolation bracket can be mounted in several different orientations for a variety of acoustic-sensitive installations. All Resilmount products are precision manufactured by Studco Building Systems for complete control over the quality of each individual piece, in order to meet or exceed the architectural specifications required of each resilient mount. The patented resilmount rubber insert has been independently tested and approved for use in the USA.

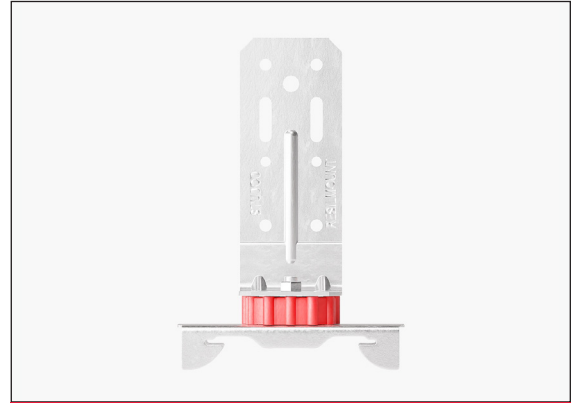

A96R

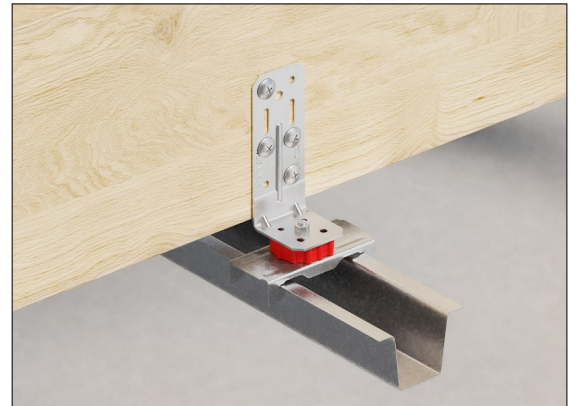

A96R INSTALLATION

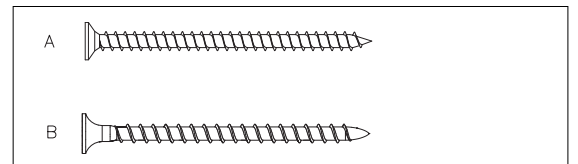

FASTENERS

Resilmount A96R

Purlin to Furring Channel Sound Isolation Bracket

SPECIFICATIONS

Code	Bracket Height	Weight Capacity (lbs)*
A96R	4 3/4"	48

*Lead time and minimum quantities may apply.

RELATED PRODUCTS

- A24R Chase Wall Joiner Sound Isolation Clip
- A48R Right Angle Sound Isolation Bracket
- A106R Purlin to Furring Channel Low Clearance Sound Isolation Clip
- A72R Double Right Angle Sound Isolation Bracket

WARRANTY

This product is covered by a year warranty. Conditions and limitations of guarantees and warranties are set out in Studco Project Guarantee certificate.

FURTHER ASSISTANCE

Contact the technical engineering team at Studco Technical Services for assistance with specifications, product selection, acoustic engineering and structural engineering enquiries.
 Tel: 800 675 8023 or email sales@resilmount.com

ACCREDITATION/CERTIFICATION

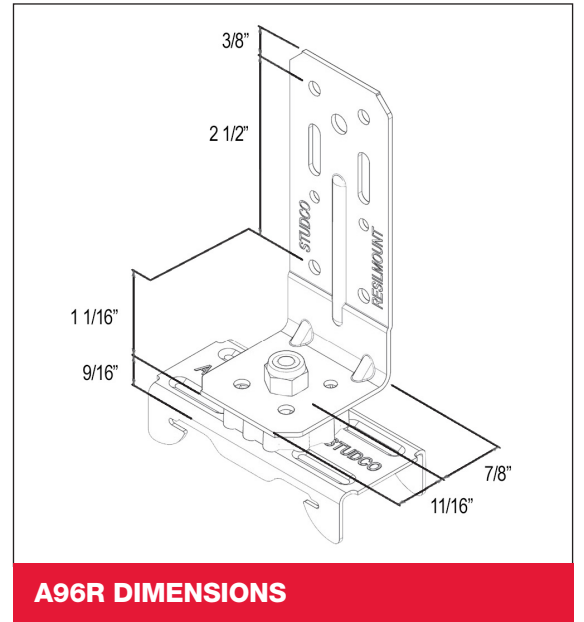

Product Datasheet